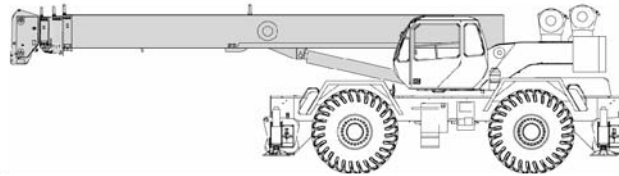

**Rough Terrain Crane Specifications | RT700****STANDARD BOOM EQUIPMENT****BOOM**

40-126' (10.67-33.53 m), four section full power boom. Telescoping is mechanically synchronized with single lever control. The synchronization system consists of a single telescope cylinder and high strength leaf chains to extend and retract the third section and the tip section. The boom is a high-strength four plate design, welded inside and out with anti-friction slide pads. Boom side plates are made with stamped impressions to reduce weight and increase strength. A single boom hoist cylinder provides for boom elevation of -4 to 78 degrees. Maximum tip height 134' (40.87 m).

**BOOM HEAD**

Welded to fourth section of boom. Five or six metallic load sheaves and two idler sheaves mounted on heavy duty, anti-friction bearings. Quick reeving boom head. Provisions made for side-stow jib mounting.

**OPTIONAL BOOM EQUIPMENT****JIBS**

32' (9.68 m) side stow swing-on one-piece lattice type jib. Single nylon sheave mounted on anti-friction bearing. Jib is offsettable at 0°, 15°, or 30°. Maximum tip height is 165' (50.42 m).

33-57' (10.15-17.30 m) side stow swing-on lattice type jib. Single nylon sheave mounted on anti-friction bearing. Jib is extendible to 57' (17.30 m) by means of a 25' (7.62 m) manual pull-out tip section, roller supported for ease of extension. Jib is offsettable at 0°, 15°, or 30°. Maximum tip height is 190' (57.91 m).

**BOOM HEAD**

Welded to fourth section of boom. Five or six nylon load sheaves and two idler sheaves mounted on heavy duty, anti-friction bearings. Quick reeving boom head. Provisions made for side-stow jib mounting.

**AUXILIARY BOOM HEAD**

Removable auxiliary boom head has single nylon sheave mounted on anti-friction bearing. Removable pin-type rope guard for quick reeving. Installs on main boom peak only. Removal is not required for jib use.

**HOOK BLOCK**

Five metallic sheaves on anti-friction bearings with hook and hook latch. Quick reeving design does not require removal of wedge and socket from rope.

**HOOK & BALL**

12 ton (10.9 mt) top swivel ball with hook and hook latch.



### STANDARD UPPERSTRUCTURE EQUIPMENT

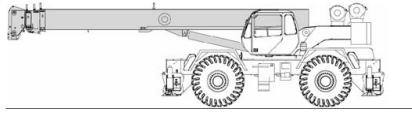

#### UPPERSTRUCTURE FRAME

All welded one-piece structure fabricated with high tensile strength alloy steel. Counterweight is bolted to frame.

#### TURNTABLE CONNECTION

Swing bearing is a single row, ball type, with internal teeth. The swing bearing is bolted to the revolving upperstructure and to the carrier frame.

#### SWING

A hydraulic motor drives a double planetary reduction gear for precise and smooth swing function. Swing speed (no load) is 2.2 rpm.

#### SWING BRAKE

Heavy duty multiple disc swing brake is mechanically actuated from operator's cab by foot pedal. Brake may be locked on or used as a momentary brake. A 360° mechanical house lock is standard.

#### RATED CAPACITY INDICATOR

Rated Capacity Indicator with visual and audible warning system and automatic function disconnects. Second generation pictographic display includes: boom radius, boom angle, boom length, allowable load, actual load, and percentage of allowable load registered by bar graph. Operator settable alarms provided for swing angle, boom length, boom angle, tip height, and work area exclusion zone. Anti-two block system includes audio/visual warning and automatic function disconnects.

#### OPERATORS CAB

Environmental cab with all steel construction, optimum visibility, tinted safety glass throughout, and rubber floor matting is mounted on vibration absorbing pads. The cab has a sliding door on the left side, framed sliding window on the right side, hinged tinted all glass skylight and removable front windshield to provide optimum visibility of the load open or closed. Hot air defroster keeps windshield clear. Acoustical foam padding insulates against sound and weather. The deluxe six-way adjustable seat is equipped with a mechanical suspension and includes head and arm rests.

#### CONTROLS

Armrest mounted dual axis controls for winch(s), swing, and boom elevation. Winch rotation indication incorporated into control handles. Armrest swings up to improve access and egress. Vernier adjustable hand throttle included. Steering column mounted turn signal, wiper, and shift controls. Switches include ignition, engine stop, lights, horn, roof window wiper, defroster, steering mode, parking brake, outriggers, 360° house lock, etc. Horn and winch speed shift switches are mounted in the levers. Foot control pedals include swing brake, boom telescope, service brake, and accelerator.

#### INSTRUMENTATION AND ACCESSORIES

In-cab gauges include air pressure, bubble level, engine oil pressure, fuel, engine temperature, voltmeter, transmission temperature, and transmission oil pressure. Indicators include low air, high water temperature, low oil pressure, high transmission temperature, and low coolant level audio/visual warning, hoist drum rotation indicator(s), and Rated Capacity Indicator. Accessories include fire extinguisher; light package including headlights, taillight, brake lights, directional signals, four-way hazard flashers, dome light, and back-up lights with audible back-up alarm; wind-shield washer/wiper; skylight wiper; R.H. and L.H. rear view mirrors; dash lights; and seat belt. Circuit breakers protect electrical circuits.

#### HYDRAULIC CONTROL VALVES

Valves are mounted on the rear of the upper structure and are easily accessible. Valves have electric/hydraulic operators and include one pressure compensated two spool valve for boom elevation and telescope. One pressure compensated two spool valve for main and auxiliary winch, and one single spool valve for swing. System provides for simultaneous operation of all crane functions. High pressure regeneration feature provides 2-speed boom extension. Quick disconnects are provided for ease of installation of pressure check gauges.

#### OPTIONAL EQUIPMENT

Auxiliary Winch • Single axis armrest mounted controllers • LP Heater/Defroster • Hydraulically powered Air Conditioner with or without hydraulic heater<sup>1</sup> Diesel Heater/Defroster • Work Lights, Rotating Beacon

### STANDARD CARRIER EQUIPMENT

#### CARRIER CHASSIS

Chassis is Terex designed with four-wheel drive and four-wheel steer (4X4X4). Has box-type construction with reinforcing cross members, a precision machined turn table mounting plate and integrally welded outrigger boxes. Decking has anti-skid surfaces, including between the frame rails, a lockable front tool storage compartment, and access steps and handles on the left and right sides and on all four corners. Lights are recessed into the outrigger boxes for protection. Air reservoir drains are collected in an easily accessible central location.

#### AXLES AND SUSPENSION

Rear axle is a planetary drive/steer type with 10.5" (0.26m) of total oscillation. Automatic oscillation lockouts engage when the superstructure is swung 10° either direction. Front axle is a planetary drive/steer type, rigidly mounted to the frame for increased stability.

#### STEERING

Hydraulic four-wheel full power steering for two-wheel, four-wheel coordinated, or four-wheel crab steer is easily controlled by steering wheel. A rear axle centering light is provided.

	Turning Radius: (to CL of outside tire)	Curb Clearance Radius
Two-wheel:	41' 7" (12.7 m)	43' 2" (13.2 m)
Four-wheel:	22' 10" (7.0 m)	24' 7" (7.5 m)

#### TRANSMISSION

Range shift type power-shift transmission with integral torque converter provides 6 speeds forward and 6 speeds reverse with neutral safety start. Four wheel drive engages automatically with low range and two wheel drive with high range. A remote mounted oil filter provides easy access. Automatic pulsating back-up alarm.



### STANDARD CARRIER EQUIPMENT (CONTINUED)

#### MULTI-POSITION OUT & DOWN OUTRIGGERS

Fully independent hydraulic outriggers may be utilized fully extended to 24 ft. (7.32 m) centerline to centerline, in their 1/2 extended position, or fully retracted for maximum flexibility. Easily removable 24" diameter Almag floats, each with an area of 452 in<sup>2</sup> (2919 cm<sup>2</sup>), stow on the outrigger boxes at their point of use. Complete controls and a sight leveling bubble are located in the operator's cab.

#### WHEELS AND TIRES

Disc type wheels with full tapered bead seat rim. 157.56" (4.0 m) wheel-base.

#### TIRES

Wide earthmover (E3) style tread tires provide life and flotation. 29.50x25, 28 P.R. - std.

#### SERVICE BRAKES

Split system air over hydraulic 18.5" (470 mm) diameter disc dual caliper brakes on all wheels.

#### PARKING BRAKE

Electrically controlled front axle mounted spring-set, air released drum type parking brake with indicator light.

#### OPTIONAL EQUIPMENT

Cold Weather Starting Aid, Immersion Heater, Pintle Hook, Clearance Lights, Front Mounted Winch - 20,000 lb (9 072 kg), Independent Rear or Four Mode Rear Wheel Steer.

#### ENGINE SPECIFICATION

- ▶ Make and Model, Cummins QSB5.9 (275 hp)
- ▶ Type 6 cylinder
- ▶ Bore and Stroke 4.02 x 4.72" (102 x 120 mm)
- ▶ Displacement 359 in<sup>3</sup> (5.9 L)
- ▶ Rated HP 275 hp (205 kw) @ 2500 rpm
- ▶ Max. Gross HP 275 hp (205 kw) @ 2300 rpm
- ▶ Max. Gross Torque 750 lb • ft (990 N•m) @ 1500 rpm
- ▶ Aspiration Turbocharged & charge air cooled
- ▶ Air filter dry type
- ▶ Electrical System 12 volt
- ▶ Alternator 102 amp
- ▶ Battery (2) 12V-1900 C.C.A.
- ▶ Fuel Capacity 80 gal (304 L)

All performance data is based on a gross vehicle weight of 94,898 lb (43 045 kg). 29.5x25 tires, 4x4 drive. Performance may vary due to engine performance. Gradeability data is theoretical and is limited by tire slip, machine stability, or oil pan design.

#### PERFORMANCE (STANDARD ENGINE)

Transmission Gear	Forward Drive	Max. Speed	Max. Tractive Effort	Gradeability @ Stall
▶ 1	4-wheel	2.1 mph (3.4 kph)	68,645 lb(31, 137 kg)	98.9%
▶ 2	4-wheel	4.4 mph (7.1 kph)	33,050 lb (14,991 kg)	34.8%
▶ 3	4-wheel	12.3 mph (19.8 kph)	11,7921b (5,349 kg)	10.5%
▶ 4	2-wheel	5.4 mph (8.4 kph)	27,7771b (12, 599 kg)	28.3%
▶ 5	2-wheel	10.9 mph (17.5 kph)	13, 3751b (6,067kg)	12.2%
▶ 6	2-wheel	25.0 mph (40.8 kph)	4,7681b (2,163 kg)	3%

### HYDRAULIC SYSTEM

#### HYDRAULIC PUMPS

Three gear type pumps, one single and two in tandem, driven off the transmission. Combined system capability is 120 gpm (455 lpm). Includes pump disconnect on winch pump

- ▶ **Main and Auxiliary winch pump**  
57.8 gpm (218.8lpm) @ 4,500 psi (316.4 kg/cm<sup>2</sup>)
- ▶ **Boom Hoist and Telescope Pump**  
42.1 gpm (159.4 lpm) @ 4,500 psi (316.4 kg/cm<sup>2</sup>)
- ▶ **Power Steering, Outrigger and Swing Pump**  
20.2 gpm (76.5lpm) @ 3,500 psi (246.1 kg/cm<sup>2</sup>)

#### FILTRATION

Full flow oil filtration system with bypass protection includes a removable 60 mesh (250 micron) suction screen-type filter and five micron synthetic depth type media replaceable return line filter.

#### HYDRAULIC RESERVOIR

All steel, welded construction with internal baffles and diffuser. Provides easy access to filters and is equipped with an external sight level gauge. The hydraulic tank is self pressurizing to aid in keeping out contaminants and in reducing potential pump cavitation. Capacity is 178 gal (674 liters). Hydraulic oil cooler is standard.

#### OPTIONAL HOIST LINE

**Main winch and optional auxiliary winch** 3/4" (19 mm) rotation resistant compacted strand 34 x 7 grade 1960. Min. breaking strength 34.5 tons (31.7 mt).

#### MAIN WINCH SPECIFICATIONS

Hydraulic winch with bent axis piston motor and planetary reduction gearing provides 2-speed operation with equal speeds for power up and down. Winch is equipped with an integral automatic brake, grooved drum, tapered flanges, standard cable roller on drum, and an electronic drum rotation indicator.

Performance	LO-Range	HI-Range
▶ Max line speed (no load)		
▶ First layer	191 fpm (9 m/min)	341 fpm (103.9 m/min.)
▶ Fifth layer	275 fpm (83.8 m/min)	489 fpm (149.0 m/min.)
▶ Max. line pull-first layer	18,450 lb (8 369 kg)	9,002 lb (4 083 kg)
▶ Max. line pull-fifth layer	12,845 lb (5 826 kg)	5,052 lb (2 846 kg)
▶ Permissible line pull	13,800 lb (6 260 kg)	

#### Drum Dimensions

- ▶ 13" (330 mm) drum diameter
- ▶ 20.16" (512 mm) length
- ▶ 12.5" (546 mm) flange dia.
- ▶ Cable: 3/4" x 600' (19 mm x 182.9 m)
- ▶ Cable type: 3/4" (19 mm) 6 x 19 IWRC XIPS, right regular lay, performed.
- ▶ Min. breaking strength 29.4 tons (26.6 mt)

#### Drum Capacity

Max. Storage: 561' (171 m)  
Max. useable: 561' (171 m)\*

\*Based on minimum flange height above top layer to comply with ANSI B30.5

#### OPTIONAL AUXILIARY WINCH

Hydraulic two-speed winch with bent axis piston motor, equal speed power up and down, planetary reduction with integral automatic brake, grooved drum with tapered flanges, drum roller, and rotation indicator.

#### Performance

- ▶ Max. line speed (no load) Fifth layer 489 fpm (149.0 m/min)
- ▶ Max. line pull First layer 18,450 lb (8 369 kg)

#### Drum Dimensions and Capacity

(Same as main winch)



## GENERAL DIMENSIONS

- Dimensions given assume the boom is fully retracted in travel position and 29.50 x 25 tires.
- Minimum ground clearance under: transmission-29.00", axle bowls-23.62", tie rods-23.88"

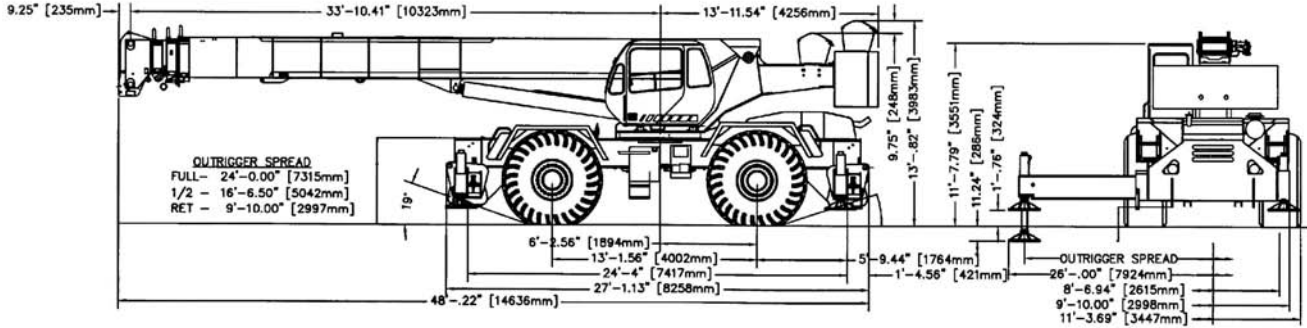

WEIGHTS & AXLE LOADS	GROSS WEIGHT LB	UPPER FACING FRONT		GROSS WEIGHT KG	UPPER FACING FRONT	
		FRONT	REAR		FRONT	REAR
Basic Crane with 15,200 lb (6 895 kg) Counterweight	+ 91,216	+ 47,047	+ 44,169	+ 41,372	+ 21,338	+ 20,033
Add Options:						
32' (9.68 m) Swing-on jib (Stowed)	+ 1,270	+ 2,524	- 354	+ 576	+ 1,145	- 161
33'-57"(10.15-17.30 m)	+ 2,170	+ 3,992	- 1,822	+ 984	+ 1,811	- 826
Swing-on Jib (Stowed)						
Auxiliary Boom Head	+ 125	+ 406	- 281	+ 57	+ 184	- 127
Auxiliary Winch with 600' of 6x19 class Wire Rope	+ 134	- 35	+ 159	+ 61	- 16	+ 72
75T (68.0 mt) 5-Sheave Hook Block	+ 1,608	+ 3,447	- 1,839	+ 729	+ 1,563	- 834
60T (54.4 mt) 5-Sheave Hook Block	+ 1,204	+ 2,581	- 1,377	+ 546	+ 1,171	- 625
20T (18.1 mt) 1-Sheave Hook Block	+ 570	+ 936	- 366	+ 259	+ 425	- 166
12T (19.9 mt) Hook and Ball (In tool box)	+ 419	+ 426	- 7	+ 190	+ 193	- 3
Pintle Hook: Front:	+ 45	+ 60	- 15	+ 20	+ 27	- 7
Rear:	+ 45	- 25	+ 70	+ 20	- 11	+ 32
Substitute:						
600' of 34x7 class spin resistant wire rope	+ 96	- 30	+ 126	+ 44	- 14	+ 57

Note: Weights are for Terex supplied equipment and are subject to 2% variation due to manufacturing tolerances.

**TEREX Cranes**  
 106-12th Street S.E.  
 Waverly, Iowa 50677-9466 USA

TEL (319) 352-3920 FAX (319) 352-5727  
 EMAIL inquire@terexwaverly.com  
 WEB terex.com

WE RESERVE THE RIGHT TO AMEND THESE SPECIFICATIONS AT ANY TIME WITHOUT NOTICE. THE ONLY WARRANTY APPLICABLE IS OUR STANDARD WRITTEN WARRANTY APPLICABLE TO THE PARTICULAR PRODUCT AND SALE. WE MAKE NO OTHER WARRANTY, EXPRESSED OR IMPLIED.